

Warning

The sensor is not a safety component according to the EU Machinery Directive.

Proper Environment

Storage temperature range: -40 ... +70 °C

Operating temperature range: -30 ... +60 °C

Humidity: 5 ... 95 % RH (non-condensing)

Laser Safety

The sensor works with a semiconductor laser at a wavelength of 660 nm (visible/red). Maximum optical power is ≤ 1 mW. The sensors fall within laser class 1.

The accessible radiation is harmless under predictable conditions. Class 1 laser devices therefore may be used without further protective measures.

A laser information sticker is enclosed:

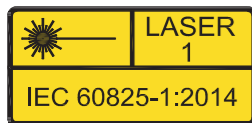

Technical Data

Model		ILR1040-10-IO-I	ILR1040-10-IO-U	ILR1041-60-IO-I	ILR1041-60-IO-U	ILR1041-150-IO-I	ILR1041-150-IO-U
Measuring range ¹⁾	Start of measuring range	0.03 m	0.03 m	-	-	-	-
	End of measuring range	10 m	10 m	-	-	-	-
	Start of measuring range with reflector film ILR-RF250	-	-	0.2 m	0.2 m	0.2 m	0.2 m
	End of measuring range with reflector film ILR-RF250	-	-	60 m	60 m	150 m	150 m
Measuring rate	Adjustable up to 333 Hz						
Maximum traversing speed	10 m/s						
Permissible ambient light	50,000 lx @ 2.5m standard white 90%, 10,000 lx @ 2.5m black 6%						
Supply voltage	18 ... 30 VDC, typ. 25 mA						
Digital interface	IO-Link 1.1 (via C/Q pin 4)						
Analog output	4 ... 20 mA (12 bits DA)	0 ... 10 V (12 bits DA)	4 ... 20 mA (12 bits DA)	0 ... 10 V (12 bits DA)	4 ... 20 mA (16 bits DA)	0 ... 10 V (16 bits DA)	0 ... 10 V (16 bits DA)
Switching output	Q1 (max. 100 mA) push-pull output (configurable) reverse polarity protected, overvoltage resistant						

1)The specified data apply at a constant room temperature of 20 °C with continuous sensor operation. Measurements were taken on a white, diffusely reflective surface (reference ceramic). Reflector film RF250

Measuring Range, Object Color

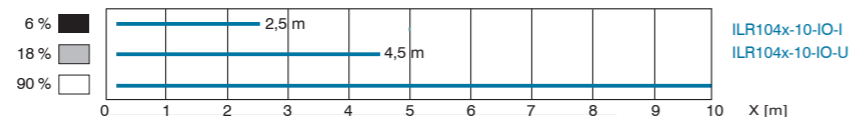

Electrical Connection

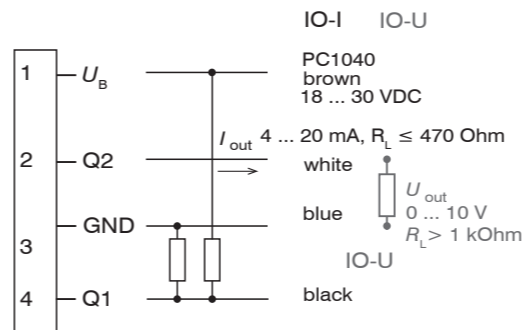

Cable socket, view onto socket side

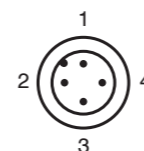

You can find more information in the interface instructions:

<https://www.micro-epsilon.com/fileadmin/download/manuals/man-optoNCDT-ILR-1040-IO--de-en.pdf>



Sensor Dimensions

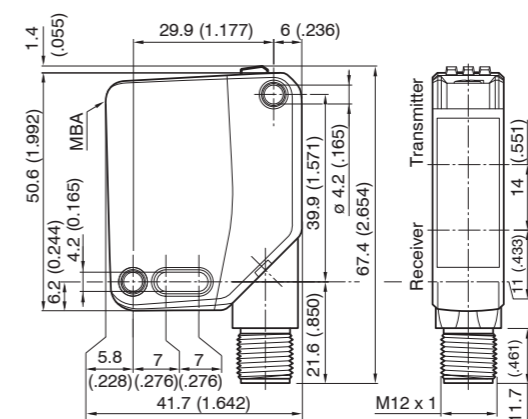

Dimensions in mm (inches, rounded off)

Your local contact:

www.micro-epsilon.com/contact/worldwide/

MICRO-EPSILON Eltrotec GmbH
Manfred-Wörner-Straße 101

73037 Göppingen / Germany

Tel. +49 (0) 7161/98872-300

Fax +49 (0) 7161/98872-303

eltrotec@micro-epsilon.de

<https://www.micro-epsilon.com>

X9771493-A022125TSw

© MICRO-EPSILON MESSTECHNIK



Setup Guide

optoNCDT ILR1040-10-IO-I /IO-U

optoNCDT ILR1041-60-IO-I /IO-U

optoNCDT ILR1041-150-IO-I /IO-U

Distance Sensor Design

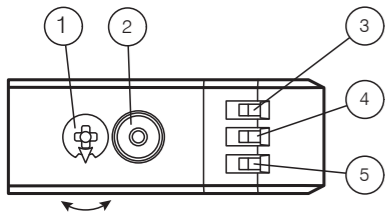

1	Mode rotary switch	
2	SET button	
3	LED analog output	Yellow
4	LED switching output	Yellow
5	Operating display	Green

	Q1B	Switching output / switching point B
	Q1A	Switching output / switching point A
	Q2A	Teach point A
	Q2B	Teach point B
	0	Key lock

Switching Output, Switching Points

A single, brief press of the SET button triggers the learning process. The relevant switching threshold A and/or B can be selected using the rotary switch for the switching output Q1. The yellow LEDs indicate the current status of the selected output. After successful teach-in, the output and LED change their status.

Incorrect teach-in is indicated by alternating flashing (8 Hz). After incorrect teach-in and the corresponding error message, the sensor continues to operate with the last valid setting (repeatable for all switching points).

Each taught-in value can be overwritten by pressing the SET button again.

The selected taught-in value can be deleted by pressing and holding the SET button for > 5 s. The LEDs will go out when the relevant value has been deleted.

The different switching points allow for different switching behaviors.

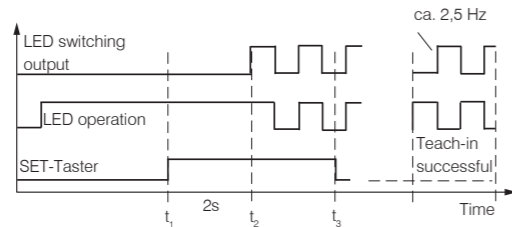

Factory Setting:

- High active (= light switching)
- Hysteresis 15 mm (0 ... 500 mm)

Window (Factory Setting)

- Switching point Q1 is 1 when the detected distance is $\geq A$ and $\leq B$
- A higher value for A or B defines an upper threshold value (no change in switching behavior/polarity)
- Values A and B define threshold values

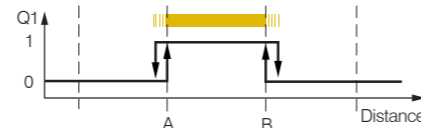

Single Point

- Q1 is 1 when the detected distance is $\leq A$
- A defines a threshold value

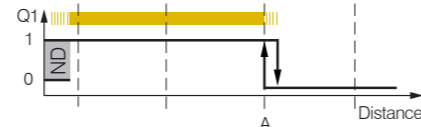

Two Point

- Q1 is 1 when the detected distance is $\leq B$ and $\geq A$ and $\geq A$
- In the range between A and B switching point, depending on the previous status
- A higher value for A or B defines an upper threshold value (no change in switching behavior/polarity)
- Signal hysteresis is not applied

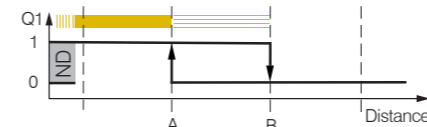

Centered Window

- Q1 is 1 when the detected distance is within the range $B \pm$ switching point 0
- For distance sensors with a defined target position (reflection sensor)
- $B \pm$ switching point 0 defines the threshold value

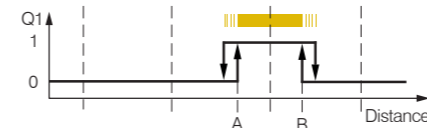

SET Button, Analog Output

The respective scaling points A and/or B can be selected using the rotary switch for the analog output Q2.

Rising ramp ($A < B$), factory setting

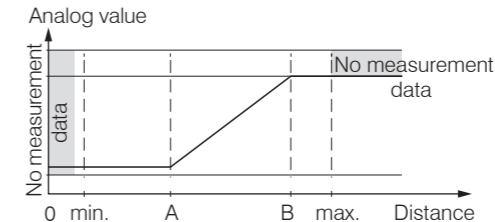

Falling ramp ($A > B$)

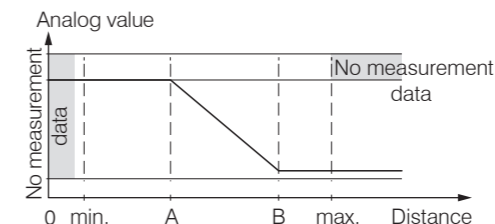

Factory setting analog output Q2:

- A = 200 mm
- B = 5000 mm

It is not possible to delete value B. You can change to "Zero-point line" mode by deleting value A.

Resetting the factory setting:

- ➡ Set the rotary switch to the position 0.
- ➡ Press and hold the SET button until the LED stops flashing in-phase (approx. 10 s).

When the green LED lights up, the procedure is complete.

Error messages:

Short circuit: In the event of a short circuit, the green LED flashes at a frequency of approx. 4 Hz.

SET error: In the event of a SET error, both LEDs flash alternately at a frequency of approx. 8 Hz.

ILR 1041-60-IO-I/IO-U achieve a measuring range of 60 m ILR 1041-150-IO-I/IO-U of 150 m with the reflector ILR-RF250. The sensors only work with a suitable reflector target plate (ILR-RF250). A white target board is available as an option for all models.