







# More Precision

**confocalDT** // Confocal chromatic sensor system



# Confocal chromatic hybrid sensors

## confocalDT IFS2403

-  Hybrid sensors  $\varnothing 8$  mm with axial or radial beam path
-  Submicron resolution
-  Suitable for precise distance measurements
-  Small light spot
-  Ideal for confined installation spaces

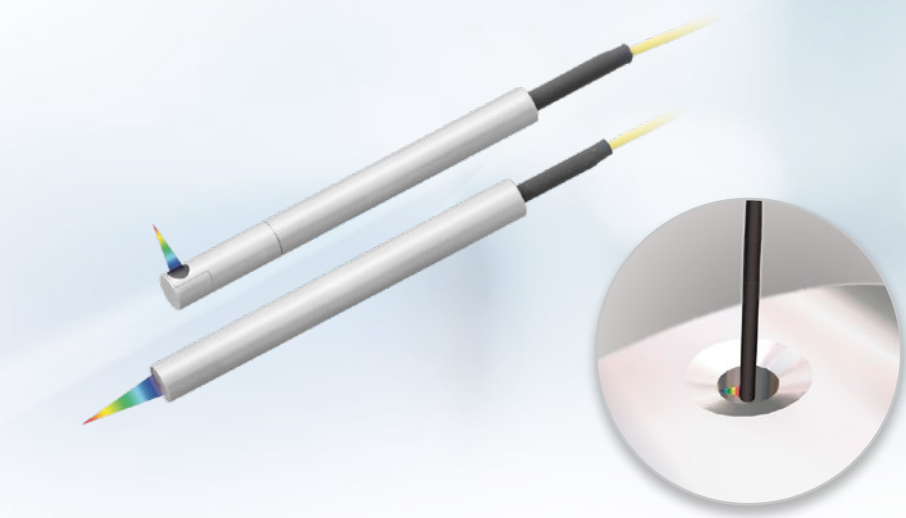

Model		IFS2403-0.4	IFS2403-1.5	IFS2403/90-1.5	IFS2403-4	IFS2403/90-4	IFS2403-10	IFS2403/90-10
Measuring range		0.4 mm	1.5 mm	1.5 mm	4 mm	4 mm	10 mm	10 mm
Start of measuring range	approx.	2.5 mm	8 mm	4.9 mm <sup>[1]</sup>	14.7 mm	12 mm <sup>[1]</sup>	11 mm	8.6 mm <sup>[1]</sup>
Resolution	Static <sup>[2]</sup>	< 8 nm	< 30 nm		< 50 nm		< 125 nm	
	Dynamic <sup>[3]</sup>	< 47 nm	< 186 nm		< 460 nm		< 950 nm	
Linearity <sup>[4]</sup>	Displacement and distance	< $\pm 0.12 \mu\text{m}$	< $\pm 0.45 \mu\text{m}$		< $\pm 1.6 \mu\text{m}$		< $\pm 4 \mu\text{m}$	
Light spot diameter		9 $\mu\text{m}$	15 $\mu\text{m}$		28 $\mu\text{m}$		56 $\mu\text{m}$	
Maximum measuring angle <sup>[5]</sup>		$\pm 20^\circ$	$\pm 16^\circ$		$\pm 6^\circ$		$\pm 6^\circ$	
Numerical aperture (NA)		0.50	0.30		0.15		0.15	
Min. target thickness <sup>[6]</sup>		0.06 mm	0.23 mm		0.6 mm		1.5 mm	
Target material		reflective, diffuse as well as transparent surfaces (e.g. glass)						
Connection		integrated optical fiber 2 m with E2000/APC connector; extension up to 50 m; bending radius: static 30 mm, dynamic 40 mm						
Mounting		Radial clamping (mounting adapter see accessories)						
Temperature range	Storage	-20 °C ... +70 °C						
	Operation	+5 °C ... +70 °C						
Shock (DIN EN 60068-2-27)		15 g/ 6 ms in XY axis, 1000 shocks each						
Vibration (DIN EN 60068-2-6)		2g/ 20 ... 500 Hz on XY axis, 10 cycles each						
Protection class (DIN EN 60529)		IP64 (front)						
Material		Stainless steel housing, glass lenses						
Weight		approx. 200 g (incl. optical fiber)						

<sup>[1]</sup> Start of measuring range measured from sensor axis

<sup>[2]</sup> Average from 2,048 values at 1 kHz, in the mid of the measuring range onto optical flat

<sup>[3]</sup> RMS noise relates to mid of measuring range (1 kHz)

<sup>[4]</sup> All data at constant ambient temperature (25  $\pm$  1 °C). Measurement on plane-parallel test glass. Acceptance report is enclosed with delivery

<sup>[5]</sup> Maximum sensor measuring angle up to which a usable signal can be achieved on reflective surfaces, with accuracy decreasing toward the limit values

<sup>[6]</sup> Pane of glass with refractive index  $n = 1.5$  in mid of measuring range

Dimensions  
(in mm, not to scale)

IFS2403-0,4 / IFS2403-1,5 / IFS2403-4 / IFS2403-10

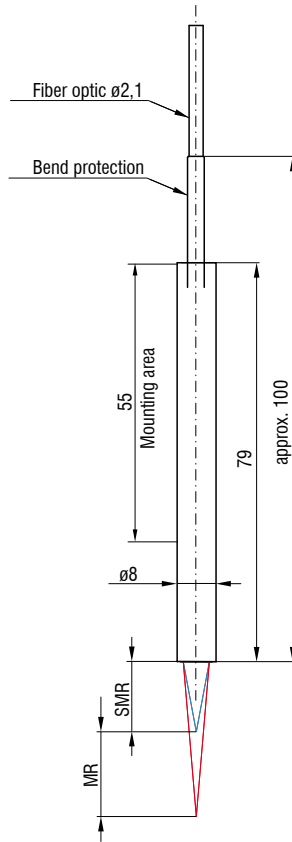

IFS2403/90-1.5

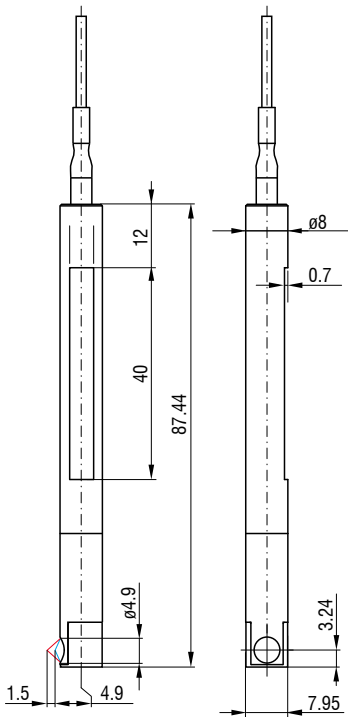

IFS2403/90-4

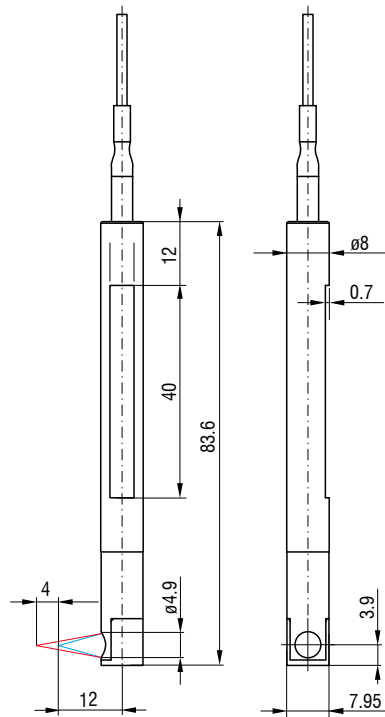

IFS2403/90-10

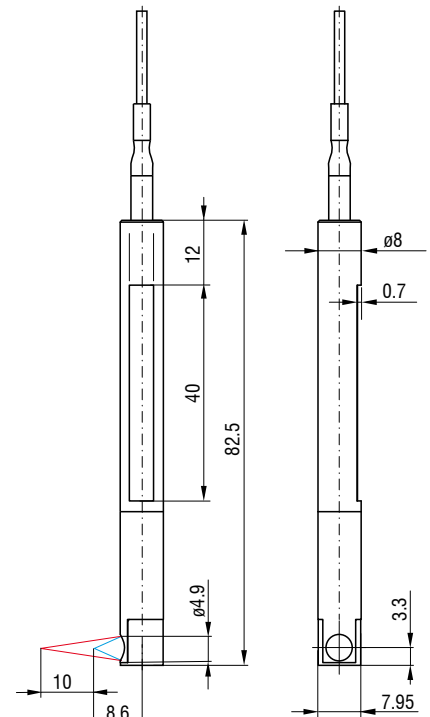

## Accessories

# Optical fiber and vacuum feedthrough

All Micro-Epsilon confocal controllers are compatible with any IFS240x sensor.

The IFS2402 and IFS2403 sensors already have integrated optical fibers



Standard fiber optics

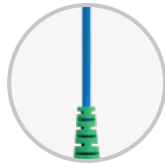

Fiber optics suitable for drag chains



Protective hose for mechanical stress



Robot-compatible fiber optics



Vacuum / UHV version HT version

Sensor-specific optical fiber <sup>1)</sup>		IFS2404 Measuring ranges 2/4	IFS2404 Measuring ranges 1/3/6/18	IFS2405	IFS2406	IFS2407	IFS2407-HT
C2404-x	with FC/APC and E2000/APC connectors; fiber core diameter 20 μm (0.3 m, 2 m, 3 m, 5 m, custom lengths up to 50 m)	✓ <sup>2)</sup>	⊘	⊘	⊘	⊘	⊘
C2401-x	with FC/APC and E2000/APC connectors (3 m, 5 m, 10 m, customer-specific length up to 50 m)						
Other versions:							
C2401/PT3-x	Optical fiber with protective hose for mechanical stress (3 m, 5 m, 10 m, customer-specific length up to 50 m)	⊘	✓	✓	✓	✓	⊘
C2401-x(01)	Optical fiber core diameter 26 μm (3 m, 5 m, 15 m)						
C2401-x(10)	Drag-chain suitable optical fiber (3 m, 5 m, 10 m)						
C2401-x(20)	Robot-suitable optical fiber (3 m, 5 m, 10 m)						
C2400-x	2x FC/APC connectors (3 m, 5 m, 10 m, customer-specific length up to 50 m) <sup>5)</sup>						
Other versions:							
C2400/PT-x	Optical fiber with protective hose for mechanical stress (3 m, 5 m, 10 m, customer-specific length up to 50 m) <sup>5)</sup>	⊘	✓	✓	✓	✓	⊘
C2400/PT-x-Vac	Optical fiber with protective hose suitable for use in vacuum (3 m, 5 m, 10 m, customer-specific length up to 50 m) <sup>5)</sup>						
C2407-x	with DIN plug and E2000/APC (0.3 m, 2 m, 3 m, 5 m)	⊘	⊘	⊘	⊘	✓ <sup>3)</sup>	⊘
C2404/PT3-x/UHV	Optical fiber with protective hose in a vacuum-compatible design (0.8 m, 1 m, custom lengths up to 50 m) <sup>4) 5)</sup>	✓	⊘	⊘	⊘	⊘	✓
C2404/PT3-xHT/UHV	Optical fiber with protective hose, vacuum-compatible design, and rated up to 200 °C (2 m, custom lengths up to 50 m) <sup>4) 5)</sup>	⊘	⊘	⊘	⊘	⊘	✓

<sup>1)</sup> Bending radius: static 30 mm, dynamic 40 mm

<sup>2)</sup> The IFS2404-2 and IFS2404/90-2 sensors come standard with a 2-meter cable. For the IFS2404-2(001) and IFS2404/90-2(001) sensors, use the C2401-x(01) cable. It has a standard length of 3 meters.

<sup>3)</sup> Only IFS2407/90-0,3

<sup>4)</sup> Bending radius: static 60 mm, dynamic 60 mm

<sup>5)</sup> Cannot be plugged directly into the controller. An FC/FC coupler or C2405 + C2401-x vacuum feedthrough is required

### Optical fiber extension for sensors

CE2402 cable with 2x E2000/APC connectors

CE2402-x Extension for optical fiber (3 m, 10 m, 13 m, 30 m, 50 m)

CE2402/PT3-x Optical fiber extension with protective hose for mechanical stress (3 m, 10 m, customer-specific length up to 50 m)

### Light source accessories

IFL2422/LED Lamp module for IFC2422 and IFC2466

IFL24x1/LED Lamp module for IFC2421 and IFC2465

**Structure of standard optical fiber**

Temperature range : -50 °C to 90 °C

Bending radius: 30/40 mm

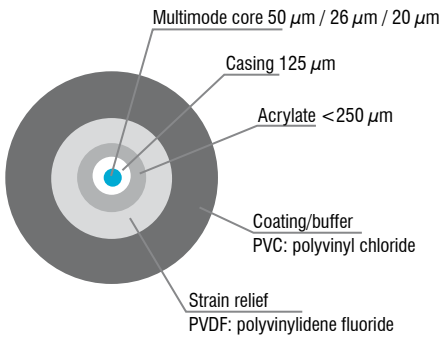

**E2000/APC Standard connector**

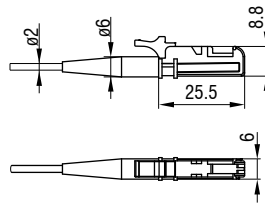

**FC/APC Standard connector**

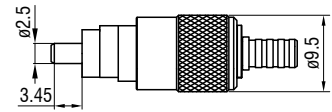

**DIN connector**

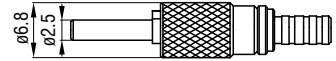

**Vacuum feedthrough**

- C2402/Vac/KF16 Vacuum feedthrough with optical fiber, 1 channel, vacuum side FC/APC non-vacuum side E2000/APC, clamping flange KF 16
- C2405/Vac/1/KF16 Vacuum feedthrough on both sides FC/APC socket, 1 channel, clamping flange type KF 16
- C2405/Vac/1/CF16 Vacuum feedthrough on both sides FC/APC socket, 1 channel, flange type CF 16
- C2405/Vac/6/CF63 Vacuum feedthrough FC/APC socket, 6 channels, flange type CF 63



**Vacuum setup**

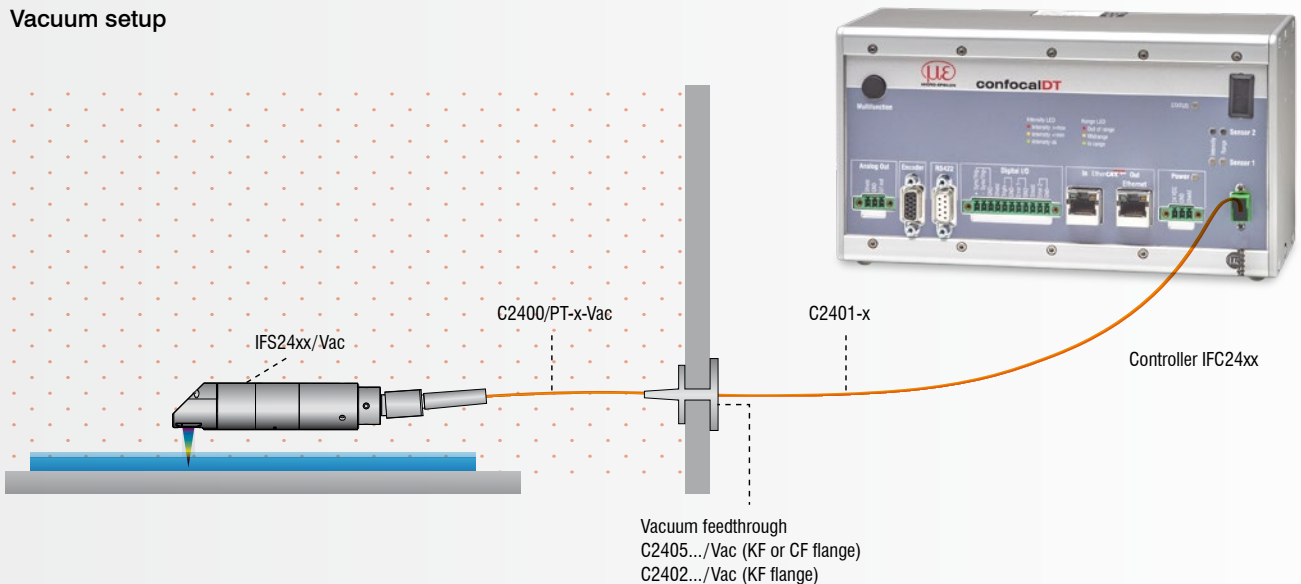

# Accessories

## Mounting adapter

### Sensor mounting adapter

MA2402 for 2402 sensors

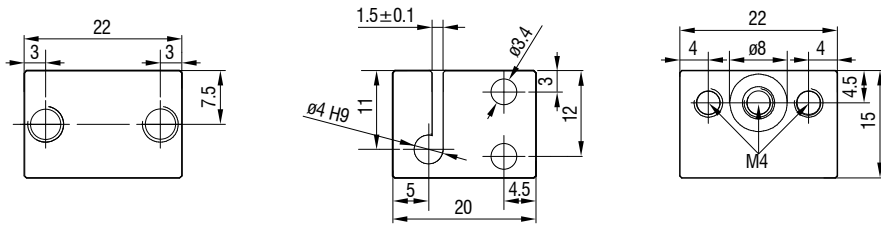

### Sensor mounting adapter

MA2403 for IFS2403 sensors

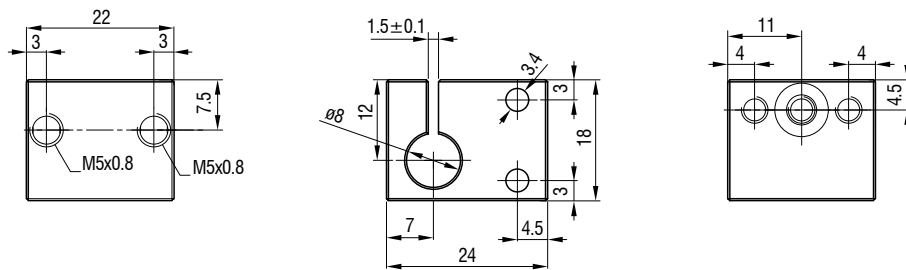

### Sensor mounting adapter

MA2404-12 for IFS2404-2 / IFS2404/90-2 / IFS2404-4 / IFS2407-0,1 / IFS2407-0,8 sensors

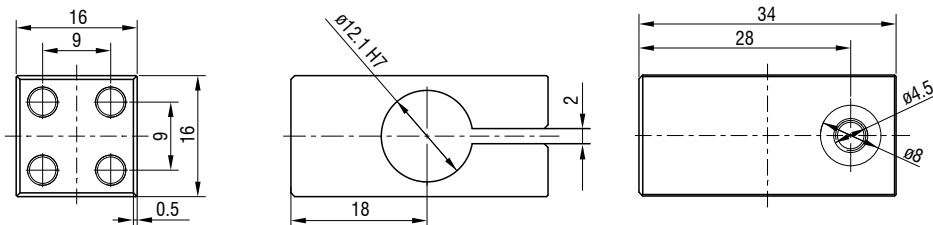

# Accessories

## Adjustable mounting adapters

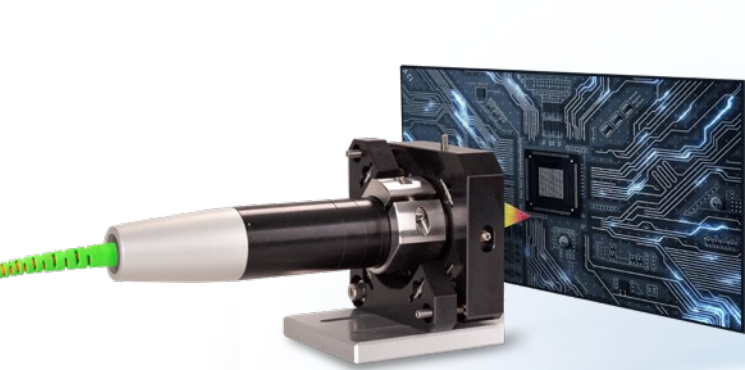

JMA-xx mounting adapter for distance measurements

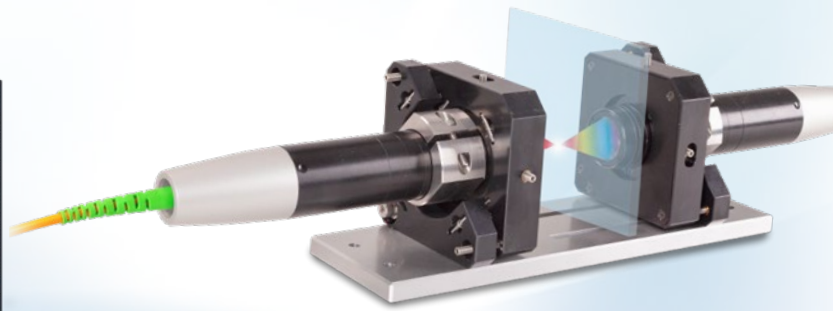

JMA-Thickness mounting adapter for two-sided thickness measurements

The adjustable JMA mounting adapter simplifies the alignment and fine adjustment of confocal sensors. The sensors are integrated and aligned directly in the machine together with the adapter. This corrects, e.g., minor deviations caused by mounting and compensates for tilted measuring objects. With two-sided thickness measurements, the JMA-Thickness mounting adapter supports the fine alignment of the two measuring points.

1 Max. shift in X  $\pm 2$  mm



2 Max. shift in Y  $\pm 2$  mm

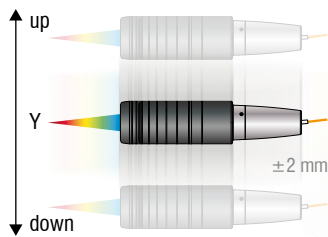

3 Max. tilt angle in X  $\pm 4^\circ$

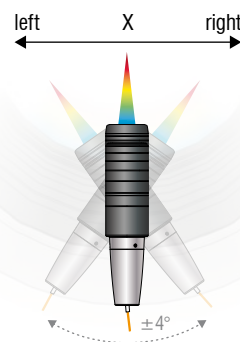

4 Max. tilt angle in Y  $\pm 4^\circ$

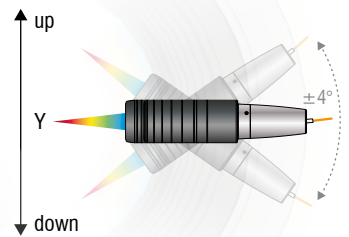

# Dimensions

## Adjustable mounting adapter JMA

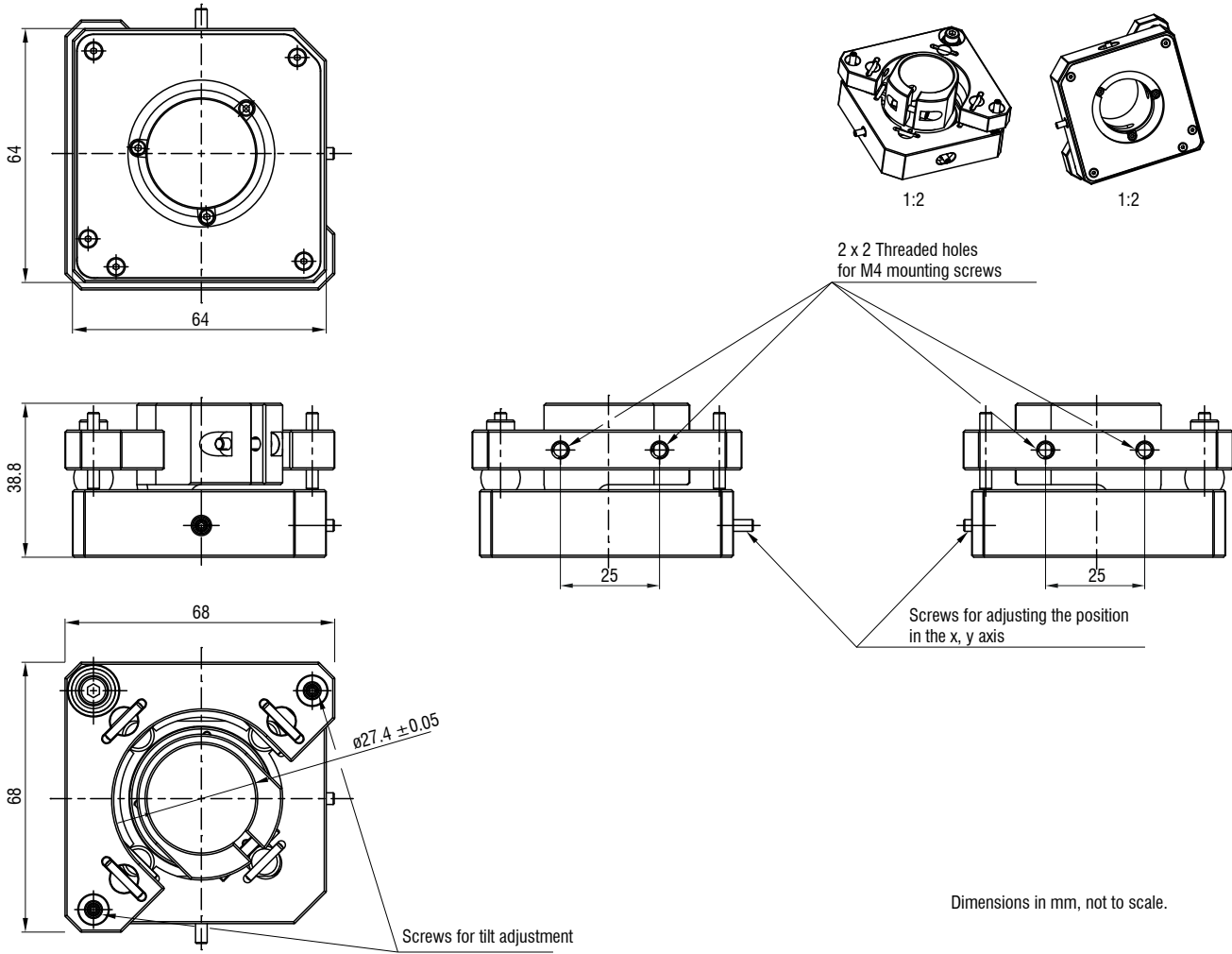

## Holder for smaller sensor diameters

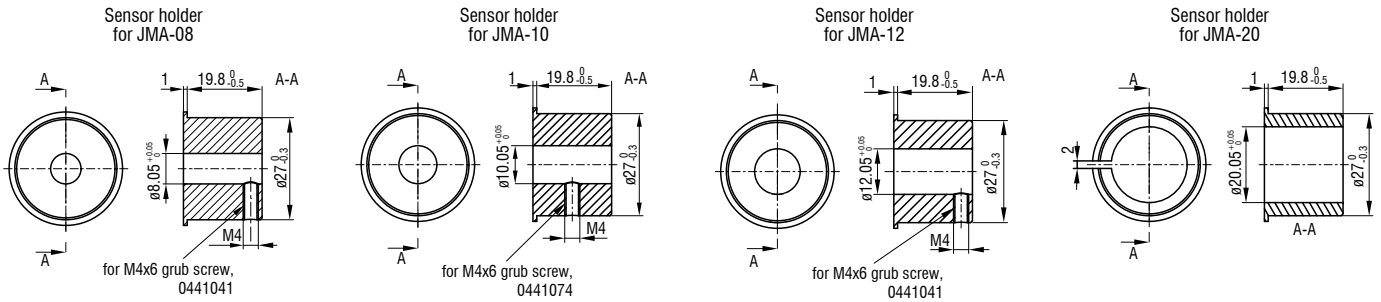

## Mounting plate JMP for JMA-Thickness

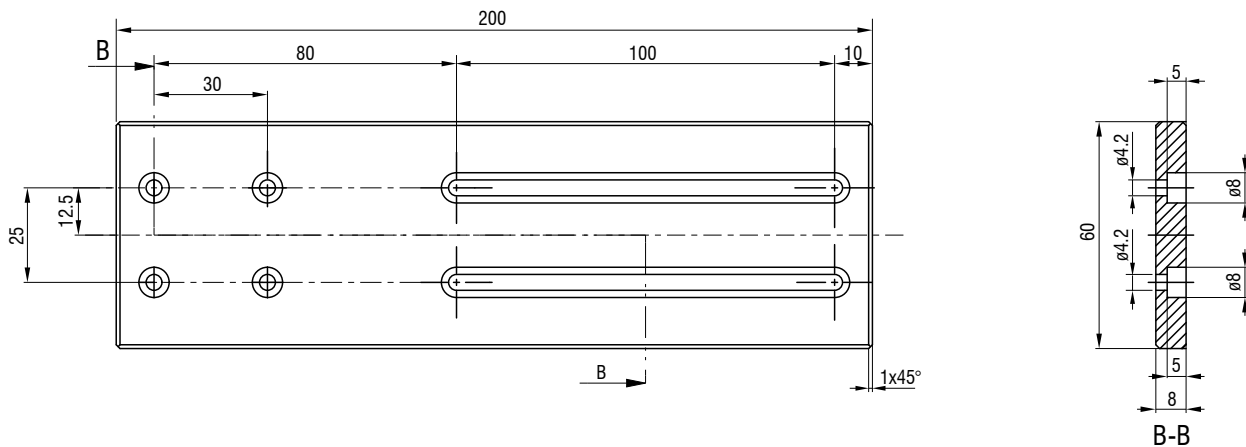

## Accessories

### Mounting adapter for individual sensors

Manual adjustment mechanism for easy and fast adjustment

Optimal sensor alignment for best possible measurement results

Ideally suitable for machine integration



Particularly for high resolution sensors with a small inclination angle, perpendicular installation is required. The JMA-xx mounting adapter enables fine alignment of the sensor to the target via the simple adjustment mechanism. This makes it easy to compensate for minor mounting deviations or tilted measuring objects.

- 1 JMA-xx
- 1 Sensor holder for smaller diameters (not with JMA-27)
- 1 Hexagon screwdriver for positioning
- Setup guide

#### Scope of supply

Model	JMA-08	JMA-12	JMA-20	JMA-27
Tilting range	X	±4° (continuously adjustable)		
	Y	±4° (continuously adjustable)		
Shifting range	X	±2 mm (continuously adjustable)		
	Y	±2 mm (continuously adjustable)		
Shock (DIN EN 60068-2-27)	15 g / 6 ms on XYZ axis, 1000 shocks each			
Vibration (DIN EN 60068-2-6)	2 g / 20 ... 500 Hz in XYZ axis, 10 cycles each			
Adjustment mechanism	Screw setting mechanism via M3x0.25 screw with hexagon socket 1.5			
Mounting	2x 2 mounting holes for M4x1			
Sensor mounting	Radial clamping for ø 8 mm	Radial clamping for ø 12 mm	Radial clamping for ø 20 mm	Radial clamping for ø 27 mm
Compatibility	confocalDT: IFS2403 series	confocalDT: IFS2404-2 /-4 IFS2407-0,1 /-0,8	confocalDT: IFS2406-2,5/VAC	confocalDT: IFS2404-1 /-3 /-6 IFS2405-0.3 IFS2405-1 IFS2406-3 IFS2406-10

#### Application examples:

##### Alignment

Subsequent correction of the mounting position

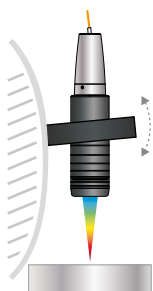

Compensates for incorrect target position

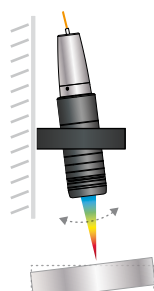

##### Positioning

Shifting the sensor to target area

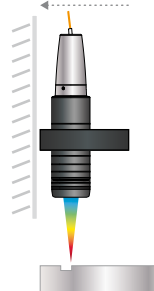

# Accessories

## Mounting adapter for two-sided thickness measurements

- Optimal alignment of the optical axes enables high precision in two-sided thickness measurements
- Pre-assembled for easy installation and fast commissioning
- Ideally suitable for machine integration

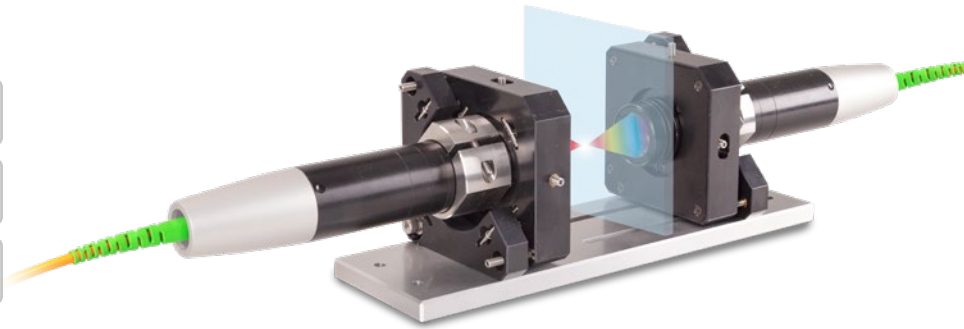

For two-sided thickness measurements, the JMA-Thickness mounting adapter supports the alignment of the measuring points to one another. This means that the measuring points are arranged absolutely congruent to each other so that the sensors are positioned exactly on an optical axis. This prevents measurements at an offset and a reliable measurement result is achieved with the highest possible precision.

When delivered, the two mounting adapters are pre-mounted on a mounting plate and aligned with one another. This simplifies installation and the measuring system can be put into operation more quickly. After installation into the machine, the plate can be removed, if necessary.

### Scope of supply

- 2 JMA-xx
- 1 JMP mounting plate
- 1 Hexagon screwdriver 1.5 mm
- 1 Allen wrench 2.5 mm
- 1 Allen wrench 3.0 mm
- 1 Setup guide
- Two optional reducing sleeves (depending on the package and the corresponding sensor)

Model	JMA-Thickness	-08	-12	-20	-27
Shock (DIN EN 60068-2-27)		15 g / 6 ms on XYZ axis, 1000 shocks each			
Vibration (DIN EN 60068-2-6)		2 g / 20 ... 500 Hz in XYZ axis, 10 cycles each			
Adjustment mechanism		Screw setting mechanism via M3x0.25 screw with hexagon socket 1.5			
Sensor mounting		Radial clamping for ø 8 mm	Radial clamping for ø 12 mm	Radial clamping for ø 20 mm	Radial clamping for ø 27 mm
Compatibility		confocalDT: IFS2403 series	confocalDT: IFS2404-2 /-4 IFS2407-0,1 /-0,8	confocalDT: IFS2406-2,5/VAC	confocalDT: IFS2404-1 / -3 / -6 IFS2405-0.3 IFS2405-1 IFS2406-3 IFS2406-10

### More precision with two-sided thickness measurements

<p><b>Without JMA-Thickness:</b> Measurement error with tilted target</p>	<p><b>Without JMA-Thickness:</b> Incorrect thickness measurement with vibrations</p>	<p><b>Without JMA-Thickness:</b> Sensors positioned incorrectly – no thickness measurement possible</p>
<p><b>With JMA-Thickness:</b> Measures exactly at the opposite position</p>	<p><b>With JMA-Thickness:</b> Sensors are on one optical axis – provides stability even with vibrating objects</p>	<p><b>With JMA-Thickness:</b> Optimal positioning support – object visible for both sensors</p>

## Sensors and Systems from Micro-Epsilon



Sensors and systems for displacement, distance and position



Sensors and measurement devices for non-contact temperature measurement



Measuring and inspection systems for metal strips, plastics and rubber



Optical micrometers and fiber optics, measuring and test amplifiers



Color recognition sensors, LED analyzers and inline color spectrometers

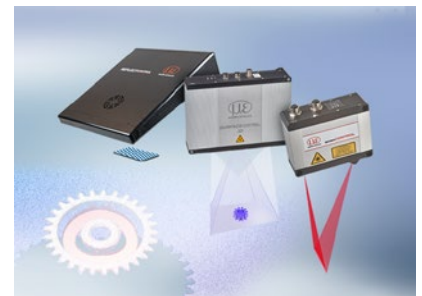

3D measurement technology for dimensional testing and surface inspection